

OWNER'S GUIDE & INSTALLATION INSTRUCTIONS

Thru-Hull *with Fairing*

Bronze HDI Tilted Element™ Transducer

Tilt Angles: 0°, 12°, 20°

Model: **B148**

U.S. Patent No. 7,369,458. UK Patent No. 2 414 077

12/10/12

17-580-01 rev. 01

Follow the precautions below for optimal product performance and to reduce the risk of property damage, personal injury, and/or death.

WARNING: Always wear safety goggles and a dust mask when installing.

WARNING: Immediately check for leaks when the boat is placed in the water. Do not leave the boat unchecked for more than three hours. Even a small leak may allow considerable water to accumulate.

CAUTION: The transducer must be installed with a fairing, so the water flowing under the transducer will be smooth.

CAUTION: The arrow on the top of the transducer must point toward the keel or centerline of the boat. This will align the angle of the element inside the transducer with the deadrise angle of your hull.

CAUTION: Never pull, carry, or hold the transducer by its cable; this may sever internal connections.

CAUTION: Never install a bronze housing on a vessel with a positive ground system.

CAUTION: Never use solvents. Cleaners, fuel, sealant, paint, and other products may contain solvents that can damage plastic parts, especially the transducer's face.

IMPORTANT: Read the instructions completely before proceeding with the installation. These instructions supersede any other instructions in your instrument manual if they differ.

Record the information found on the cable tag for future reference.

Part No. _____ Date _____ Frequency _____ kHz

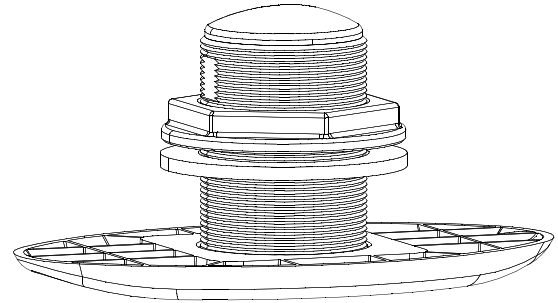

Applications

- Bronze housing recommended for fiberglass or wood hulls. *Never install a bronze housing in a metal hull, because electrolytic corrosion will occur.*

Match Tilt Angle of Transducer to Deadrise

Be sure the tilt angle of your transducer model matches the deadrise angle of your boat at the mounting location. The tilt angle is printed on the top of the transducer (see Figure 1). To measure the deadrise angle of your hull at the selected mounting location, use an angle finder (see Figure 2).

- 0° models—For hull deadrise angles from 0° to 7°
- 12° models—For hull deadrise angles from 8° to 15°
- 20° models—For hull deadrise angles from 16° to 24°

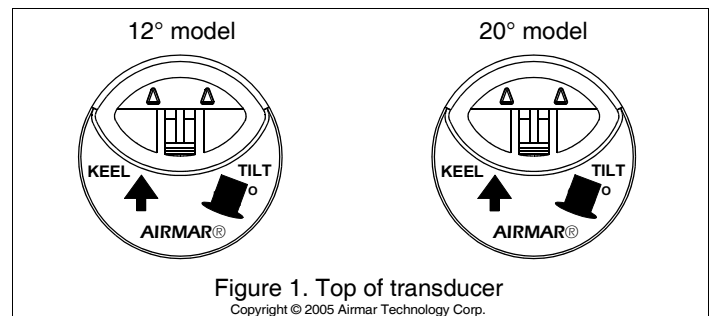

Figure 1. Top of transducer
Copyright © 2005 Airmar Technology Corp.

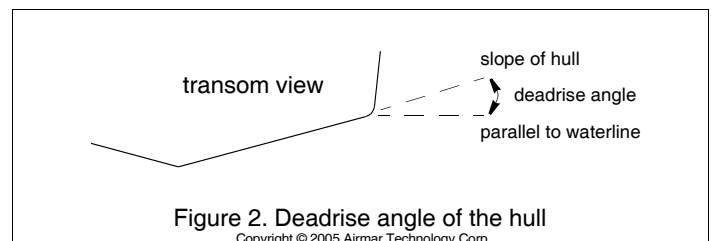

Figure 2. Deadrise angle of the hull
Copyright © 2005 Airmar Technology Corp.

Tools & Materials

Safety goggles
 Dust mask
 Angle finder
 Electric drill with 10mm (3/8") or larger chuck capacity
 Drill bit 3mm or 1/8"
 Hole saw 60mm or 2-3/8"
 Sandpaper
 Mild household detergent or weak solvent (such as alcohol)
 Marine sealant (suitable for below waterline)
 Slip-joint pliers
 Grommet(s) (some installations)
 Cable ties
 Water-based anti-fouling paint (**mandatory in salt water**)
 Installation in a cored fiberglass hull (see page 3):
 Hole saw for hull interior 80mm or 3-1/8"
 Fiberglass cloth and resin
 or Cylinder, wax, tape, and casting epoxy

Mounting Location

CAUTION: Do not mount in line with or near water intake or discharge openings or behind strakes, fittings, or other hull irregularities that will disturb the water flow.

CAUTION: Do not mount in line with trailer rollers or bunks that may damage the transducer's face.

- The water flowing under the hull must be smooth with a minimum of bubbles and turbulence (especially at high speeds).
- The transducer must be continuously immersed in water.
- The transducer beam must be unobstructed by the keel or propeller shaft(s).
- Choose a location away from interference caused by power and radiation sources such as: the propeller(s) and shaft(s), other machinery, other echosounders, and other cables. The lower the noise level, the higher the echosounder gain setting that can be used.
- Choose an accessible spot inside the vessel with adequate headroom for the height of the housing and tightening the nut.
- The starboard side of the hull where the propeller blades are moving downward is preferred.

Hull Types (see Figure 3)

- **Displacement hull powerboats**—Locate amidships near the centerline.
- **Planing hull powerboats**—Mount well aft, near the centerline, and *well inboard of the first set of lifting strakes* to ensure that the transducer will be in contact with the water at high speeds.
Outboard and I/O—Mount just forward of the engine(s).
Inboard—Mount well ahead of the propeller(s) and shaft(s).

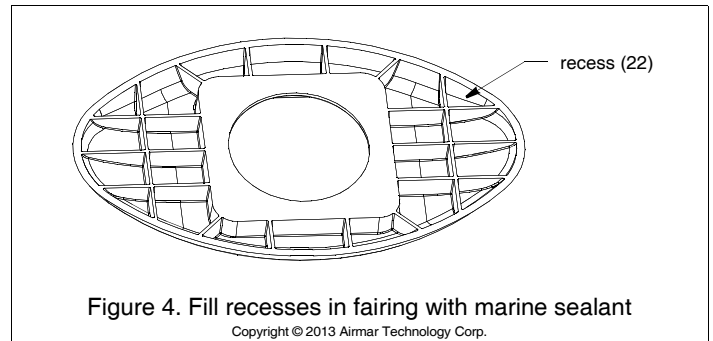
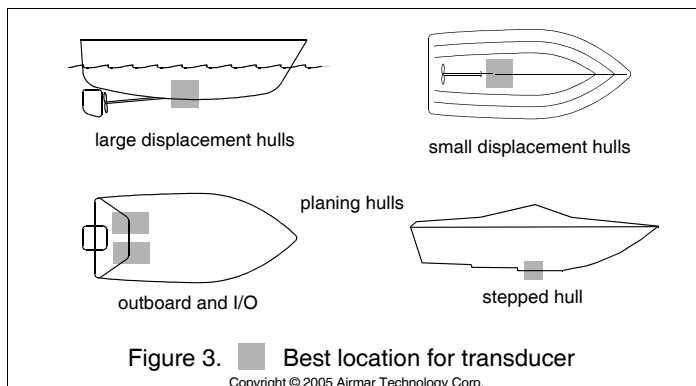

Stepped hull—Mount just ahead of the first step.

Boat capable of speeds above 25kn (29MPH)—Review the installation location and operating results of similar boats before proceeding.

Installation

Hole Drilling

Cored fiberglass hull—Follow separate instructions on page 3.

1. Drill a 3 mm or 1/8" pilot hole from inside the hull. If there is a rib, strut, or other hull irregularity near the selected mounting location, drill from the outside.
2. Using the 60mm or 2-3/8" hole saw, cut a hole from outside of the hull *perpendicular* to the hull surface.
3. Sand and clean the area around the hole, inside and outside, to ensure that the sealant will adhere properly to the hull. If there is any petroleum residue inside the hull, remove it with either mild household detergent or a weak solvent (alcohol) before sanding.

Bedding

CAUTION: Be sure the surfaces to be bedded are clean and dry.

1. Apply a layer of marine sealant to the surface of the fairing that will contact the hull (see Figure 4). **Be sure to fill all 22 of the recesses in the fairing.**
2. Apply a 2mm (1/16") thick layer of marine sealant around the flange of the housing that contacts the fairing and up the sidewall of the housing (see Figure 5). The sealant must extend 6mm (1/4") higher than the combined thickness of the fairing, hull, washer, and hull nut. This will ensure there is marine sealant in the threads to seal the hull and to hold the hull nut securely in place.
3. Thread the transducer cable through the hole in the fairing. Then seat the transducer firmly within the square recess in the fairing.

Installing

1. From outside the hull, thread the cable through the mounting hole.
2. Push the transducer with the fairing in place through the mounting hole using a pushing twisting motion to squeeze out excess sealant (see Figure 6). Be sure the long ends of the fairing are pointing fore and aft and the rounded side of the *transducer's face* points toward the keel/centerline of the boat (see Figure 5).
3. From inside the boat, slide the washer and hull nut along the cable and onto the housing (see Figure 6). **Be sure the arrow on the top of the transducer (and the cable exit) is pointing toward the KEEL/centerline of the boat** (see Figure 1). This will align the angle of the element inside the transducer with the deadrise angle of the hull.

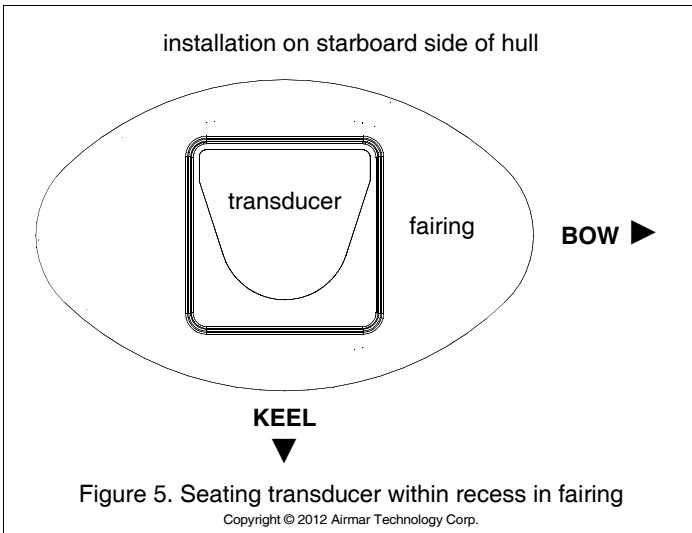

4. Screw the hull nut in place (see Figure 6). Tighten it with slip-joint pliers.
Cored Fiberglass Hull—Do not over tighten, crushing the hull.
Wood hull—Allow the wood to swell before tightening the hull nut.
5. Remove any excess marine sealant on the outside of the hull and fairing to ensure smooth water flow under the transducer.

Cable Routing & Connecting

CAUTION: If your transducer came with a connector, do not remove it to ease cable routing. If the cable must be cut and spliced, use Airmar's splash-proof Junction Box No. 33-035 and follow the instructions provided. Removing the waterproof connector or cutting the cable, except when using a water-tight junction box, will void the sensor warranty.

1. Route the cable to the instrument, being careful not to tear the cable jacket when passing it through the bulkhead(s) and other parts of the boat. Use grommets to prevent chaffing. To reduce electrical interference, separate the transducer cable from other electrical wiring and the engine. Coil any excess cable and secure it in place using cable ties to prevent damage.
2. Refer to the echosounder owner's manual to connect the transducer to the instrument.

Checking for Leaks

When the boat is placed in the water, **immediately** check around the transducer for leaks. Note that very small leaks may not be readily observed. Do not leave the boat in the water for more than 3 hours before checking it again. If there is a small leak, there may be considerable bilge water accumulation after 24 hours. If a leak is observed, repeat "Bedding" and "Installing" **immediately** (see page 2).

Installation in a Cored Fiberglass Hull

The core (wood or foam) must be cut and sealed carefully. The core must be protected from water seepage, and the hull must be reinforced to prevent it from crushing under the hull nut allowing the housing to become loose.

CAUTION: Completely seal the hull to prevent water seepage into the core.

1. Drill a 3mm or 1/8" pilot hole from inside the hull (see Figure 7). If there is a rib, strut, or other hull irregularity near the selected

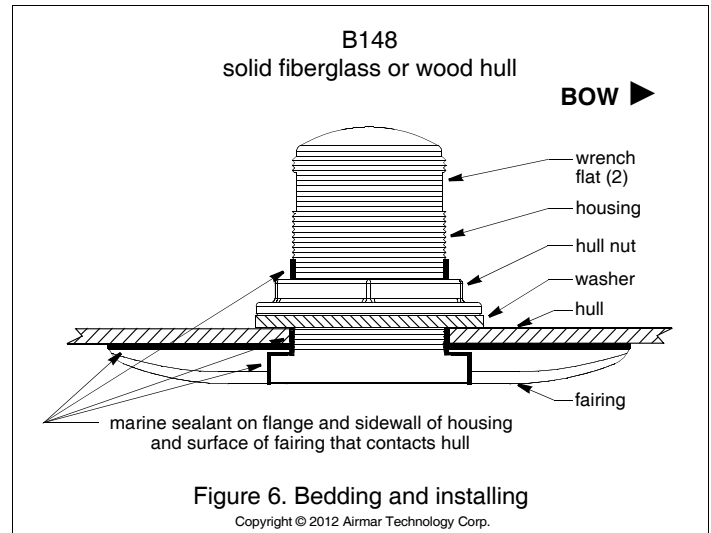

- mounting location, drill from the outside. (If the hole is drilled in the wrong location, drill a second hole in a better location. Apply masking tape to the outside of the hull over the incorrect hole and fill it with epoxy.)
2. Using the appropriate size *outside hull* hole saw, cut a hole from outside the hull through the *outer skin* only (see table on page 1).
 3. From inside the hull, using the 80mm or 3-1/8" hole saw, cut through the *inner skin* and most of the core. The core material can be very soft. Apply only light pressure to the hole saw after cutting through the *inner skin* to avoid accidentally cutting the *outer skin*.
 4. Remove the plug of core material, so the *inside* of the outer skin and the inner core of the hull is fully exposed. Sand and clean the inner skin, core, and the outer skin around the hole.
 5. If you are skilled with fiberglass, saturate a layer of fiberglass cloth with a suitable resin and lay it inside the hole to seal and strengthen the core. Add layers until the hole is the correct diameter.
 Alternatively, a hollow or solid cylinder of the correct diameter can be coated with wax and taped in place. Fill the gap between the cylinder and hull with casting epoxy. After the epoxy has set, remove the cylinder.
 6. Sand and clean the area around the hole, inside and outside, to ensure that the marine sealant will adhere properly to the hull. If there is any petroleum residue inside the hull, remove it with either mild household detergent or a weak solvent (alcohol) before sanding.
 7. Proceed with "Bedding" on page 2.

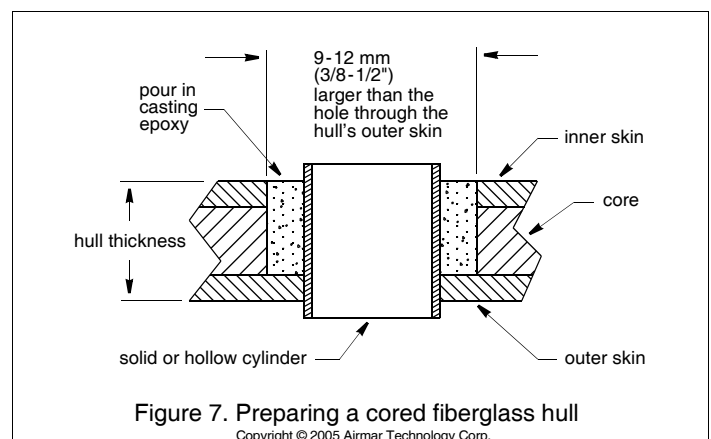

Maintenance, Replacement & Parts

Anti-fouling Paint

Surfaces exposed to salt water must be coated with anti-fouling paint. *Use water-based anti-fouling paint only.* Never use ketone-based paint, since ketones can attack many plastics possibly damaging the transducer. Reapply anti-fouling paint every 6 months or at the beginning of each boating season.

Cleaning

Aquatic growth can accumulate rapidly on the transducer's face, reducing its performance within weeks. Clean the surface with a Scotch-Brite® scour pad and mild household detergent, *being careful to avoid making scratches.* If the fouling is severe, lightly wet sand it with fine grade wet/dry paper.

Replacement Transducer & Parts

The information needed to order a replacement transducer is printed on the cable tag. Do not remove this tag. When ordering, specify the part number, date, and frequency in kHz. For convenient reference, record this information on the top of page one.

Lost, broken, and worn parts should be replaced immediately.

Model	Hull Nut	Washer
B148	02-133-01	09-813-01

Obtain parts from your instrument manufacturer or marine dealer.

Gemeco
(USA)

Tel: 803-693-0777
Fax: 803-693-0477
email: sales@gemeco.com

Airmar EMEA
(Europe, Middle East, Africa)

Tel: +33.(0)2.23.52.06.48
Fax: +33.(0)2.23.52.06.49
email: sales@airmar-emea.com